

*Reprinted from the IRE TRANSACTIONS OF THE
PROFESSIONAL GROUP ON CIRCUIT THEORY*
Volume CT-3, Number 4, December, 1956
PRINTED IN THE U.S.A.

A Study of Rough Amplitude Quantization by Means of Nyquist Sampling Theory*

BERNARD WIDROW†

IN MANY system and signal analysis problems, it is convenient to work with the probability density distributions of signals rather than with the signals themselves. Thus, the new "signals" are these probability densities, and the results of analyses are statistical.

This approach has been helpful in providing an under-

* Manuscript received by the PGCT, August 8, 1956. The research reported in this paper was supported jointly by the U. S. Army, Navy, and Air Force, under contract with Mass. Instit. Tech., Cambridge, Mass. This paper is an abstraction of a dissertation submitted in partial fulfillment of the requirements for the degree of doctor of science.

† Dept. Elec. Eng., M. I. T.

standing of the process of amplitude quantization. Quantization or round-off is a nonlinear operation that is effected whenever a physical quantity is represented numerically. The value of a measurement is designated by an integer corresponding to the nearest number of units contained in the measured physical quantity. Incorporation of such a process within a system makes the entire system nonlinear and difficult to deal with by any direct analytical procedure. The statistical approach greatly reduces complexity by giving average results which are very often adequate for system evaluation and design. Statistical descriptions of quantization turn out

to be fairly easy to get because the quantizer output probability density distribution is obtained by a linear sampling process upon the input distribution density.

THE QUANTIZER

A rounding-off process may be represented symbolically as in Fig. 1. For purposes of analysis, it has been found convenient to define the quantizer as a nonlinear operator having the input-output relation of Fig. 1. Its output X' is a single-valued function of the input X , and it has an "average gain" of unity. An input lying somewhere within a quantization "box" of width q will yield an output corresponding to the center of that box (i.e., the input is rounded to the center of the box). More general quantizers such as those in Fig. 2 (a) and (b) could be obtained by preceding and following the quantizer of Fig. 1 with instantaneous linear amplifiers (multiplying factors) and adding dc levels to the quantizer input and output (tailoring averages).

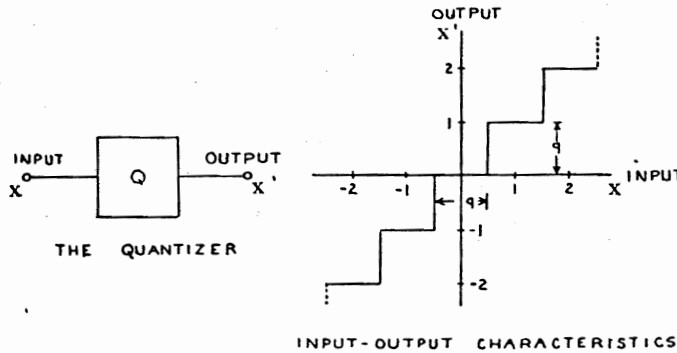

Fig. 1—The quantizer; input-output characteristics.

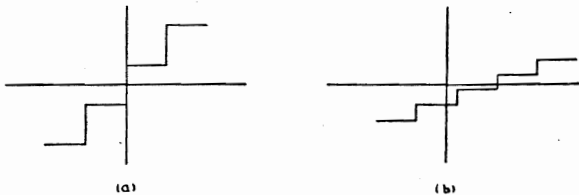

Fig. 2—More general quantizers.

A quantizer may be defined to process continuous data or sampled data. In this paper, the inputs to quantizers will be sampled. Many of the conclusions drawn carry over to the quantization of continuous data, however.

A STATISTICAL DESCRIPTION OF THE QUANTIZATION PROCESS

First-Order Statistics

If the samples of some continuous variable are random and statistically independent of each other, a first-order probability density $W(X)$ completely describes this process. The characteristic function of $W(X)$ is its Fourier transform:

$$F_x(\xi) = \int_{-\infty}^{\infty} W(X) e^{-i\xi X} dX. \tag{1}$$

A quantizer input variable may take on a continuum of magnitudes, while the output variable can assume only discrete states. The probability density of the output $W'(X')$ consists of a series of impulses that are uniformly spaced along the amplitude axis, each one centered in a quantization box.

Fig. 3 shows how the output distribution is derived from that of the input. Since any event occurring within a quantization box is always "reported" as at the center of that box, each impulse has a magnitude equal to the area under the probability density $W(X)$ within the bounds of the box. The impulse distribution $W'(X')$ has a periodic characteristic function, being the Fourier transform of a series of impulses having uniform spacing q . The point of view developed by W. K. Linvill for the study of amplitude sampling as an amplitude-modulation process with an impulse carrier has been found to be most useful in the derivation of $W'(X')$ and its more general counterparts. The necessary aspects of Linvill's ideas will be developed next.

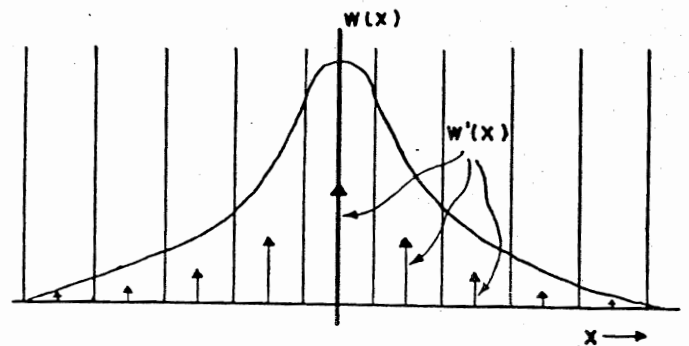

Fig. 3—Area sampling used in the derivation of $W'(X)$.

Amplitude Sampling Treated as Linear Impulse Modulation: The process of periodically sampling a function $f(t)$ is the same as multiplying it by a series of impulses of unit area which are spaced uniformly. The impulse carrier of fundamental frequency $\Omega = 2\pi/T$ may be represented by the Fourier series in (2).

$$f^*(t) = [f(t)][\text{impulse carrier}] = [f(t)]\left[\frac{1}{T}\right] \sum_{-\infty}^{\infty} e^{jn\Omega t}. \tag{2}$$

It is the sum of an infinite number of sinusoidal carriers with uniform frequency spacing Ω which, when modulated by $f(t)$, develop identical "sidebands" about each frequency $n\Omega$. The pattern of these sidebands is the same as that of the Fourier transform of $f(t)$. $F^*(j\omega)$, the Fourier spectrum of the series of impulses $f^*(t)$, is the sum of a periodic array of sections, separated by the frequency Ω , where the typical repeated section is the same as $(1/T)F(j\omega)$, the spectrum of the envelope of the pulses. If it were possible to separate the zeroth section of $F^*(j\omega)$ from the rest, it would be possible to recover an envelope

from its samples. This can be done with an "ideal low-pass filter" if the sections are distinct and do not overlap. The gain as a function of frequency for such a filter together with $F^*(j\omega)$ are shown in Fig. 4. If $F^*(t)$ is applied to the input of the low-pass filter of Fig. 4, the output will be $f(t)$. Since the impulse response of the ideal low-pass filter is $[\sin(\pi t/T)]/(\pi t/T)$, it follows by linearity that the envelope of the impulses is a sum of these, properly weighed and spaced in time, as shown in Fig. 5.

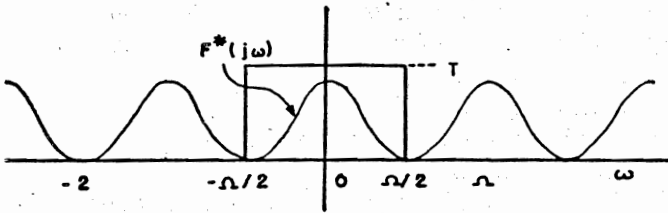

Fig. 4—Recovery of envelope from samples in the frequency domain.

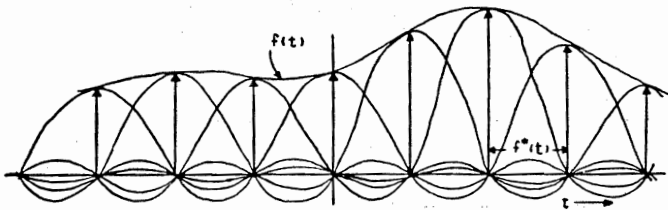

Fig. 5—Recovery of envelope from samples in the time domain

The low-pass filter is an interpolater that yields $f(t)$ as long as $f(t)$ has no significant harmonic content at higher frequency than $\Omega/2$. This is the Nyquist bandwidth restriction on $f(t)$.

Derivation of the First-Order Probability Density of a Quantized Variable: The distribution of a quantizer output $W'(X')$ consists of "area samples" of the input distribution density $W(X)$. The quantizer may be thought of as an area sampler acting upon the "signal," the probability density $W(X)$. Fig. 6 shows how $W'(X')$ may be constructed by sampling the difference $D(x + q/2) - D(x - q/2)$, where $D(x)$ is the distribution, the integral of the distribution density. Fig. 7 is a block schematic diagram of this process, showing how $W(X)$ is first modified by a linear filter of "gain" $[\sin(q\xi/2)]/(q\xi/2)$ and then sampled to give $W'(X')$.

When the radian "fineness" ϕ , 2π times the reciprocal of the box width, is twice as high as the radian "frequency" of the highest "frequency" component contained in the shape of $W(X)$, it is possible to recover $W(X)$ from the quantized distribution $W'(X')$ by inverse transforming the quotient of a typical section of $F_r(\xi)$ and $[\sin(q\xi/2)]/(q\xi/2)$.

The characteristic function of the distribution density of the sum of two random independent variables is the product of the individual cf's. Fig. 8 shows the distribution $Q(n)$ and its characteristic function. $Q(n)$ will be shown

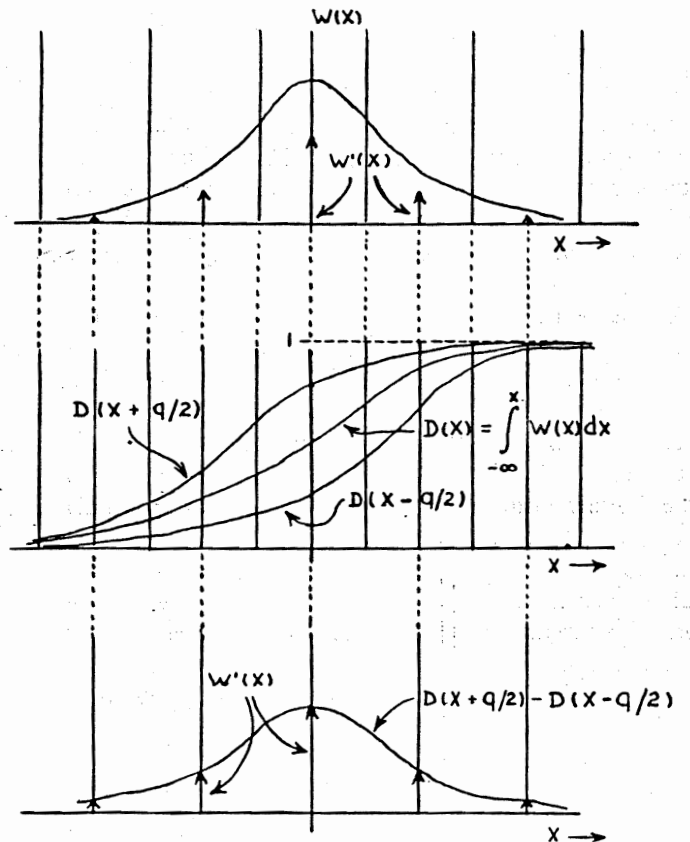

Fig. 6—Construction of area samples.

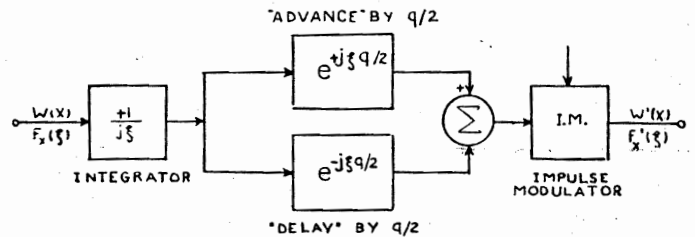

Fig. 7—Block diagram of the area sampling of Fig. 8.

to be the distribution of quantization noise. Its cf is $F_r(\xi) = [\sin(\pi\xi/\phi)]/(\pi\xi/\phi) = [\sin(q\xi/2)]/(q\xi/2)$. If purely random independent noise of distribution $Q(n)$ were added to a signal of distribution $W(X)$, their sum would have a cf $F_r(\xi) [\sin(\pi\xi/\phi)]/(\pi\xi/\phi)$, which is identical with the typical section of $F_r(\xi)$. The derivatives of a cf at the origin determine moments. It follows that the moments of a quantized signal are the same as if the quantizer were a source of independent random additive noise of distribution $Q(n)$ provided that Nyquist's restriction on $W(X)$ is met. If the moments of $W(X)$ are m_1, m_2, \dots , and the moments of $W'(X')$ are μ_1, μ_2, \dots , they may be expressed in terms of each other and the box size q as in (3). Advantage is taken of the facts that $Q(n)$ has a second moment of $1/12 q^2$ and a fourth moment of $1.80 q^4$.

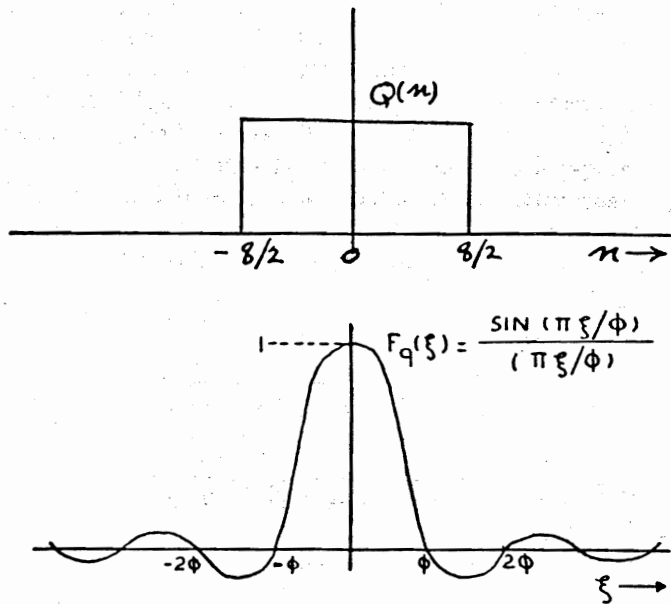

Fig. 8—The distribution of quantization noise and its characteristic function.

$$\begin{aligned}
 m_1 - \mu_1 &= 0 \\
 m_2 - \mu_2 &= -\frac{1}{12} q^2 \\
 m_3 - \mu_3 &= -\frac{1}{4} \mu_1 q^2 \\
 m_4 - \mu_4 &= -\frac{1}{2} \mu_2 q^2 + \frac{7}{240} q^4 \\
 &\vdots
 \end{aligned}
 \tag{3}$$

The right-hand sides are the well known Sheppard corrections for grouping.

It is now possible to derive $W'(X')$ from $W(X)$. The understanding of the quantizer would be complete if it were true that the quantization noise (the difference between input and output) were independent of the quantizer input. This is not true, however. Not only is the quantization noise statistically related to the input, but it is also causally related. Since the output of a quantizer is a single-valued function of the input, any given input yields a definite output and a definite noise.

The *distribution density* of the noise itself will be shown to be $Q(n)$, independent of the *distribution density* of the quantizer input (as long as the Nyquist restriction is satisfied). Their causal tie will show up later when joint input-output distribution densities are derived.

Derivation of the Probability Density of Quantization Noise: Quantization noise is always the difference between an input variable and the value of the box to which it has been assigned. The distribution of quantization noise resulting from events assigned to the zeroth box may be constructed by plotting $W(-X)$ between $-q/2 < X < q/2$. Likewise, the noise distribution resulting from events in the first box may be obtained by considering $W(-X)$ for values $-3q/2 < X < -q/2$, recentered to

the origin. Events taking place in the various boxes are exclusive of each other. The probability of a given noise magnitude arising is the sum of the probabilities of that noise from each box. Fig. 9 shows how the distribution of quantization noise is constructed from $W(-X)$.

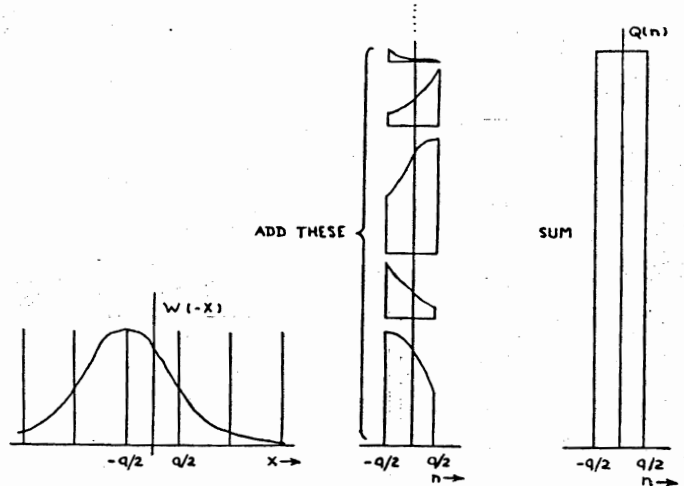

Fig. 9—Construction of distribution of quantization noise.

Since the development of the distribution of quantization noise (Fig. 9) is an additive linear process, the quantization noise distribution is the sum of the distributions of noise corresponding to constituents that are added to get $W(X)$. All that needs be considered is the quantization of the basic form $(\sin(\pi X/q))/(\pi X/q)$. The strips as in Fig. 9 are added to give the quantization noise distribution which turns out to be precisely flat-topped.

An arbitrary distribution satisfying the Nyquist condition is the sum of a series of $(\sin(\pi X/q))/(\pi X/q)$'s, where each gives a flat-topped distribution of quantization noise. The sum of flat-topped distributions is flat-topped. If the distribution density of a signal being quantized is $W(X)$, and the quantization grain is fine enough to satisfy the Nyquist restriction, the distribution of the noise introduced by the quantizer will be flat-topped. This distribution is $Q(n)$, shown in Fig. 8.

Derivation of the Joint Probability Density of the Quantizer Input and Output: A most general statistical description of a device having a random stationary output is the joint distribution between input and output. From this, the output distribution, input distribution, the difference (between input and output) distribution, and the joint distribution between input and difference may be determined. Any one of the joint distributions will determine all the rest, but at least one joint distribution need be known for a complete statistical picture. Infinite numbers of joint distributions could give the same input, output, and difference distribution densities, so that the latter are not sufficient for a complete understanding.

A study of Fig. 10 shows how a joint in-out distribution

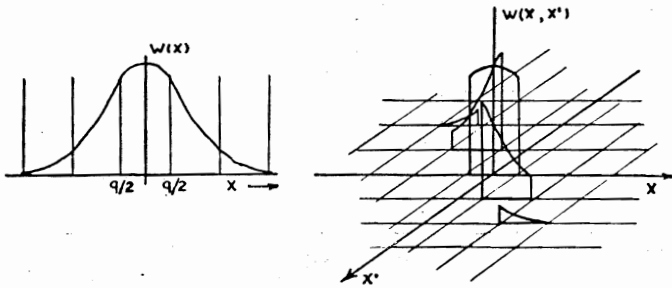

Fig. 10—Formation of joint in-out distribution from quantizer input distribution.

$W(X, X')$ is derived from a given input distribution $W(X)$. The strips of $W(X)$ are placed at the values of X' to which they correspond. Consider next the situation shown in Fig. 11. For every value of X , all values of noise are possible between $\pm q/2$ because the noise is independent of X . The joint distribution (Fig. 12) between X and $(X + n)$ shows this, whereas any plane parallel to the $(X + n)$ and w axes cuts a flat-topped section from the surface of joint probability $w(X, X + \text{noise})$. The surface of joint probability is everywhere parallel to the $X + n$ axis. The projection of the surface on the $X - w$ plane has the same shape as $W(X)$ and has an area of $1/q$. The total volume under the surface is unity.

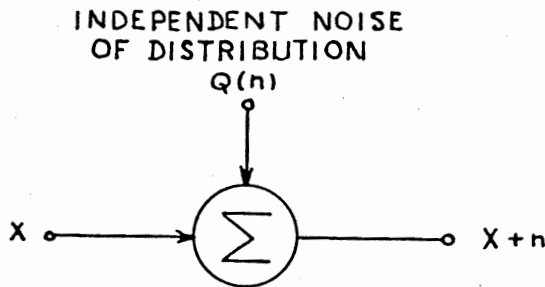

Fig. 11—Addition of independent quantization noise.

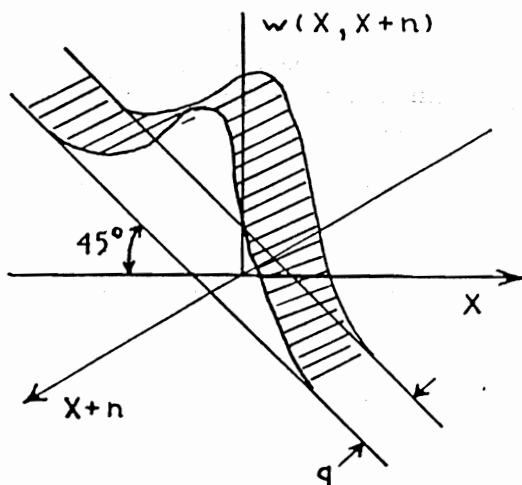

Fig. 12—Joint in-out distribution for a quantizer and for a source of additive independent quantization noise.

A study of Figs. 10 and 12 shows that the strips of Fig. 10 are sections of the three-dimensional surface of Fig. 12 (if first multiplied in amplitude by q) cut by a series of planes parallel to the W and X axes with spacing q along the $X + n$ axis. The strips of Fig. 10 are thus the results of the amplitude modulation of a periodic carrier, which is a series of uniformly-spaced impulse sheets, by an envelope which is the joint probability surface. It should be possible to deduce the joint characteristic function of the distribution $W(X, X')$ from that of $w(X, X + n)$. At the same time, the ways in which quantization is akin to the addition of random independent noise as in Fig. 11 should be detected.

The methods of amplitude sampling may readily be generalized to handle sampling by impulse sheets. Each sheet extends to infinity in both directions, and has a unit volume per unit length. The Fourier series for the amplitude sheets $Z(X, X')$ is

$$Z(X, X') = \sum_{n=-\infty}^{\infty} 1/q e^{-in\pi x'} \quad (4)$$

Z appears to be one-dimensional, because there is no variation with X . If ξ_a is the variable that X transforms into, and ξ_b is the variable that X' transforms into, the two-dimensional spectrum of $Z(X, X')$ is a string of impulses having the spacing ϕ along the ξ_b axis. Each impulse has the amplitude $1/q$. When a carrier having this spectrum is modulated by an envelope $w(X, X + n)$, the resulting spectrum is periodic along ξ_b , and aperiodic along ξ_a . The shape of a typical section is the same as the spectrum of $w(X, X + n)$. The whole series of sections results from the convolution of the two two-dimensional spectra. Since the sections of $w(X, X + n)$ are to be first multiplied by q , the factor $1/q$ is compensated for and the value of $F_{x,x'}(\xi_a, \xi_b)$ is 1 at the origin. All characteristic functions must have the value 1 at their origins in order that the total volume under their probability densities be unity.

It is of interest to derive the typical section of $F_{x,x'}(\xi_a, \xi_b)$, the Fourier transform of $w(X, X + n)$ which is the joint distribution between the input and the input plus an independent noise of distribution $Q(n)$ as in Fig. 11. A joint cf of two variables may be deduced from the characteristic functions resulting from sums of various proportions of the two variables. A block diagram illustrating this technique is given in Fig. 13. Formally

$$F_{x,x+n}(\xi_a, \xi_b) = \iint_{-\infty}^{\infty} w(X, X + n) e^{j[X\xi_a + (X+n)\xi_b]} dX d(X + n) \quad (5)$$

also,

$$F_z(\xi) = \iint_{-\infty}^{\infty} w(X, X + n) e^{j[k_1 X + k_2 (X+n)]} dX d(X + n). \quad (6)$$

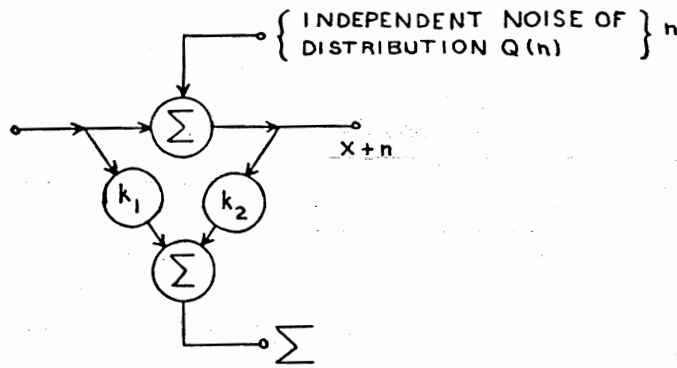

Fig. 13—Flow diagram useful in calculation of $F_{x,x+n}(\xi_a, \xi_b)$.

$F_x(\xi)$ can be readily evaluated and leads to $F_{x,x+n}(\xi_a, \xi_b)$ if the substitution is made, $k_1\xi = \xi_a$, $k_2\xi = \xi_b$. Any ξ_a, ξ_b can be obtained by choice of k_1, k_2 , and ξ . The sum Σ equals $(k_1 + k_2)X + k_2n$. The cf of X is $F_x(\xi)$, and the cf of the independent noise is $F_n(\xi)$.

$$\therefore F_x(\xi) = F_x[(k_1 + k_2)\xi]F_n(k_2\xi)$$

whence

$$\begin{aligned} F_{x,x+n}(\xi_a, \xi_b) &= F_x(\xi_a + \xi_b)F_n(\xi_b) \\ &= F_x(\xi_a + \xi_b) \frac{\sin(\pi\xi_b/\phi)}{(\pi\xi_b/\phi)}. \end{aligned} \quad (7)$$

$F_{x,x'}(\xi_a, \xi_b)$, the joint cf of the input and output of a quantizer is now expressible in terms of the cf of the quantizer input, $F_x(\xi)$.

$$\begin{aligned} F_{x,x'}(\xi_a, \xi_b) &= \sum_{n=-\infty}^{\infty} F_x(\xi_a + \xi_b + n\phi) \frac{\sin[\pi(\xi_b + n\phi)/\phi]}{[\pi(\xi_b + n\phi)/\phi]} \\ &= \sum_{n=-\infty}^{\infty} F_x(\xi_a + \xi_b + n\phi) \frac{\sin(\pi\xi_b/\phi + n\pi)}{(\pi\xi_b/\phi + n\pi)}. \end{aligned} \quad (8)$$

This is a complete statistical description of the quantizer for first-order (uncorrelated) statistics. Fig. 14 is a sketch of the joint cf $F_{x,x'}(\xi_a, \xi_b)$ which is the Fourier transform of the joint input-output distribution shown in Fig. 10.

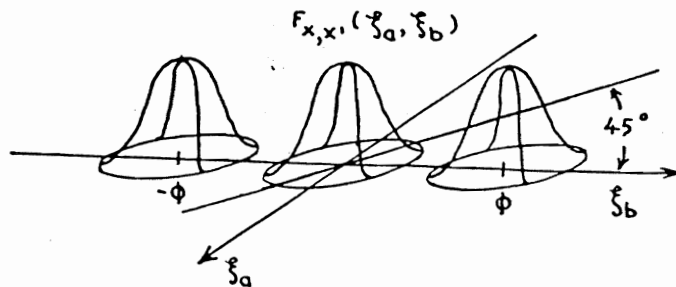

Fig. 14—Joint input-output characteristic function of a quantizer with a first-order random input.

The joint and self moments depend only upon the slopes (partial derivatives) of $F_{x,x'}(\xi_a, \xi_b)$ at the origin, and are unaffected by the periodicity of that function as long as

there is no overlap. It may be concluded that with respect to all detectable moments, quantization is the same as addition of random independent noise of distribution $Q(n)$, as long as the Nyquist restriction on $W(X)$ is satisfied.

The impulse distribution of the quantizer output, and the distribution of the quantizer noise $Q(n)$ may be rederived readily from $F_{x,x'}(\xi_a, \xi_b)$. A plane perpendicular to the ξ_a, ξ_b plane through the ξ_b axis intersects the joint input-output of $F_{x,x'}(\xi_a, \xi_b)$, giving a section which is $F_x(\xi_b)$, the cf of the output (see Fig. 14). As determined previously, the cf $F_x(\xi_b)$ is periodic of frequency ϕ where each section is identical with the cf of the sum of the quantizer input and independent quantization noise. Likewise, a plane perpendicular to the ξ_a, ξ_b plane through the ξ_a axis gives an intersection which is $F_x(\xi_a)$, the cf of the quantizer input.

A section of $F_{x,x'}(\xi_a, \xi_b)$ through the F axis and a 45° line in the $\xi_a - \xi_b$ plane as shown in Fig. 14, when projected either upon the $F - \xi_a$ plane or upon the $F - \xi_b$ plane gives the cf of the distribution of quantization noise (the distribution of $X' - X$). That the cut is at 45° insures the periodicity of the joint cf to have no effect upon the distribution of quantization noise. This distribution is therefore the same as the distribution of added noise in Figs. 11 and 13, being $Q(n)$, as shown previously.

The description of the quantizer response to first order statistics is complete and useful in itself. However, in order to understand the behavior of the quantizer in systems, particularly in feedback systems, it is necessary to consider how the quantizer reacts to correlated (high-order) input samples. The methods already developed will be extended to handle multidimensional input distributions. It has been shown that, in many respects, quantization is the same as addition of a random independent noise. Conditions will be shown under which quantization of correlated samples will be very much like addition of random independent uncorrelated noise of distribution $Q(n)$.

Higher Order Statistical Inputs

If the random quantizer input variable X is second order, (the simplest Markov process), a joint distribution density $W(X_1, X_2)$ is required to completely describe its statistics. X_1 and X_2 are an adjacent sample pair. The distribution of the output is $W'(X'_1, X'_2)$. The joint distribution between output and input is $W(X_1, X'_1, X_2, X'_2)$, having cf $F_{x_1, x'_1, x_2, x'_2}(\xi_{1a}, \xi_{2a}, \xi_{1b}, \xi_{2b})$. In order to sketch the joint distribution, five dimensions are needed. Some other way to illustrate its significant features will be sought.

$W(X_1, X_2)$ may be resolved into a two-dimensional sum of a series of $\sin X/X$'s (which is analogous to the previous one-dimensional case) provided a two-dimensional Nyquist restriction is satisfied. The cf of $W(X_1, X_2)$ is a sum of the separate components because of the linearity of the

Fourier transform. The quantization process is a linear operation upon probability distributions and characteristic functions. As a matter of fact, any situation in which a stationary random signal, even though the operation upon the signals may be nonlinear and have memory, has the characteristic that a linear operation is performed upon the input distribution to give the output distribution. The output and joint distribution of a quantizer are the sums of the corresponding distributions that could result from each component of the input distribution acting separately. It is necessary here to consider nonphysical distribution densities that not only have areas and volumes different from unity, but also have regions of negative density.

The Fourier transform of $W(X_1, X_2)$ is (9).

$$F_{x_1, x_2}(\xi_1, \xi_2) = \iint_{-\infty}^{\infty} W(X_1, X_2) e^{j(X_1 \xi_1 + X_2 \xi_2)} dX_1 dX_2. \quad (9)$$

If this cf is negligible outside the range $-\phi/2 < \xi_1, \xi_2 < \phi/2$ where $\phi = 2\pi/q$, a two-dimensional Nyquist restriction is satisfied. $W(X_1, X_2)$ may be thought of as a sum (10) where each coefficient A_{kl} is the value (amplitude sample) of $W(X_1, X_2)$ at $X_1 = kq$ and $X_2 = lq$.

$$W(X_1, X_2) = \sum_{k=-\infty}^{\infty} \sum_{l=-\infty}^{\infty} A_{kl} \frac{\sin \pi(X_1/q + k)}{\pi(X_1/q + k)} \cdot \frac{\sin \pi(X_2/q + l)}{\pi(X_2/q + l)}. \quad (10)$$

All that needs to be considered to be perfectly general is how the quantizer acts upon an input distribution such as the k, l term of the above sum.

Start with a special case, the 0, 0 term, a two-dimensional "(sin X/X)" centered at the origin. Such a distribution is a degenerate second order, clearly that of first-order statistics, and already examined completely. The adjacent samples X_1 and X_2 are statistically independent of each other, and so are their quantization noises. Periodicities of "frequency" ϕ in the joint input-output cf must exist along the output variable axes ξ_{1b} and ξ_{2b} . There is no periodic variation of this joint cf with the input variables ξ_{1a} and ξ_{2a} . The quantization noise, which is first order, is also expressed here as being degenerate second order.

The more general problem, that of quantization of the two-dimensional "(sin X/X)" distribution component centered at $X_1 = kq$ and $X_2 = lq$ presents no new difficulties. This situation cannot be distinguished from that of quantizing (with identical quantizers) two first-order jointly-related variables X_1 and X_2 as shown in Fig. 15, except that the possibility of having different averages for X_1 and X_2 is included. This could not arise in physical stationary processes where X_1 and X_2 are adjacent samples of the same random process. It should be noticed that X_1 and X_2 are actually statistically independent of each other since their joint distribution is factorable. It

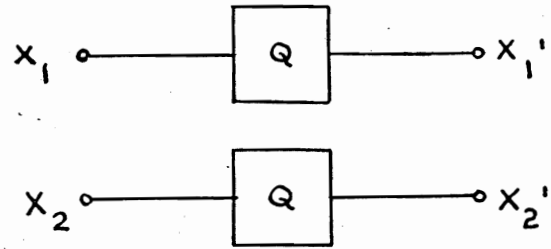

Fig. 15—Representation of the quantization of a second-order signal as the separate quantization of two jointly-related first-order signals.

is no surprise then that the quantization noise due to the k, l component turns out to be first order. The quantization process is the same as for the 0, 0 component because X_1 and X_2 are shifted by integral numbers of quantization boxes. Any such shift signifying an integral increment to the average of the quantizer input is always accompanied by an identical shift in the quantizer output. It follows that the joint input-output cf due to the k, l component has a typical section that is identical with that which would result singularly if the quantizer were replaced by a source of first order quantization noise. Linearity of the quantization process insures that the joint input-output cf for any second-order input distribution density quantized sufficiently fine to satisfy the Nyquist condition will have a typical section which is the same as the cf resulting if the quantizer were replaced by purely random quantization noise.

Fig. 15 may be modified to include 3 or more jointly-related first-order signals to represent higher-order processes. By arguments similar to those of the second-order process, a most general result may be induced: If the probability density distribution of an n -th order quantizer input has an n -dimensional cf that is negligible outside the range $-\phi/2 < \xi_{1a} \cdots \xi_{na} < \phi/2$, the joint cf between the quantizer output and input, a function of $2n$ variables $\xi_{1a}, \xi_{1b}, \cdots, \xi_{na}, \xi_{nb}$, is periodic of radian fineness ϕ along the axes $\xi_{1b}, \xi_{2b}, \cdots, \xi_{nb}$ and aperiodic along the axes $\xi_{1a}, \xi_{2a}, \cdots, \xi_{na}$, having a typical repeated section which is the same as the joint cf between the quantizer input signal and that input plus independent first-order noise of distribution $Q(n)$. A sketch of this for a first-order quantizer input is already shown in Fig. 14. When the multi-dimensional Nyquist restriction is met, all self and joint moments are unaffected if the quantizer is replaced by a source of first-order independent noise of distribution $Q(n)$. These moments, being determined by derivatives of the cf at its origin, are not affected by the periodicities when there is no appreciable overlap. The periodicities in the cf domain correspond to the regularly-spaced impulses in the quantizer output distribution density.

APPLICATIONS

Sensitivity of the Nyquist Test to Distribution Properties

To what extent the Nyquist condition is met as a func-

tion of the quantization fineness is a question that naturally arises. This will be answered for several cases of Gaussian statistics which are important in quantizer system analysis and which will show qualitatively what is to be expected for other kinds of smooth distributions.

Consideration of the first-order Gaussian cf shows that $F_x(\xi)$ will not go to zero outside of any finite band about its origin. However, it acquires negligible proportions very rapidly, going down with $e^{-\xi^2\sigma^2/2}$. σ is the root mean square of the Gaussian signal X . If we let the quantization box size $q = \sigma$, then the error made by assuming that the cf obeys the Nyquist restriction may be estimated from consideration of Fig. 16 where the cf of quantized first-order Gaussian statistics is shown. Each section, repeated with radian fineness $\phi = 2\pi/q = 2\pi/\sigma$, is of the form $e^{-\xi^2\sigma^2/2} [\sin(\pi\xi/\phi)]/(\pi\xi/\phi)$. The errors in the moments of the quantized statistics when evaluated by assuming that the quantization noise is independent and of the distribution $Q(n)$ are due to the contributions of the overlap to the derivatives of the typical section at the origin. Because X was chosen with zero average, the typical repeated cf section is even (symmetrical), causing the contributions to the odd derivatives to cancel, while the contributions to the even derivatives reinforce. The theoretical errors in all odd moments are zero. The errors in mean square and in mean fourth that result have been calculated for several box sizes.

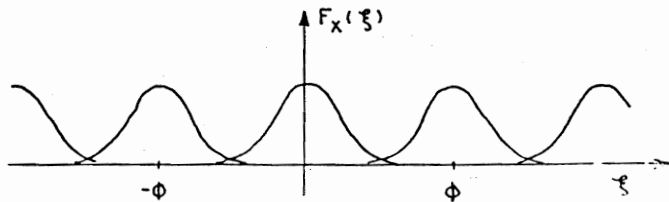

Fig. 16—Characteristic function of first-order Gaussian distribution after quantization.

Errors in analysis are extremely small when $q = \sigma$. They remain moderately small when the quantization is as rough as $q = 2\sigma$, but increase rapidly as the roughness increases further. When $q = \sigma$, the error in the mean square is 10^{-6} per cent of the mean square of the input, and about 10^{-5} per cent of the mean square of the quantization noise. These percentages climb to 3 and 9 per cent respectively when q is increased to 2σ . Such errors are very tolerable, being suprisingly small for quantization that rough. The error in mean fourth is $3(10)^{-5}$ per cent of the mean fourth of the quantizer input, $6(10)^{-2}$ per cent of the mean fourth of $Q(n)$ when $q = \sigma$. The error in mean fourth becomes large for $q = 2\sigma$, being 17 per cent of the mean fourth of the input and 250 per cent of the mean fourth of $Q(n)$.

The accuracy of this description of first-order statistics as reflected in the accuracy of the moments of the quantizer

output for Gaussian input is sufficiently great until the box size is as big as two standard deviations. From there on, the Nyquist restriction breaks down rapidly.

It was held that quantization noise is first order and uncorrelated although the quantizer input may be highly correlated, for fine quantization. Just how fine this has to be as a function of the correlation coefficient of a second-order Gaussian input will give a general indication of the sensitivity of the statistical independence of quantization noise to quantization box size.

The general k, l moment of a second-order process is given by (11).

$$\overline{X_1^k X_2^l} = \frac{1}{(-j)^{(k+l)} \partial \xi_1^k \partial \xi_2^l} f_{z_1, z_2}(\xi_1, \xi_2) \Big|_{\xi_1 = \xi_2 = 0} \quad (11)$$

Its errors when calculated (as above) are due to the contributions of overlap to this derivative at the origin. Of interest is the error in the correlation $(\overline{X_1 X_2})$, the 1, 1 moment. This error is equal in magnitude to the correlation in the quantization noise. A plot of the normalized correlation of quantization noise (the ratio of the joint first moment to the mean square) as a function of the normalized correlation coefficient of the second-order Gaussian distribution of the input (the ratio of the correlation coefficient $(\overline{X_1 X_2}) \equiv \sigma_{12}$ to the mean square σ^2) is shown in Fig. 17. A good approximation for the correlation of quantization noise is (12).

$$(\text{normalized correlation}) \approx e^{-4\pi\sigma^2/\sigma^2(1-\sigma_{12}/\sigma^2)} \quad (12)$$

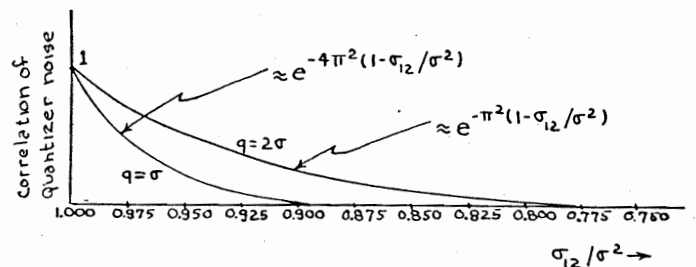

Fig. 17—Correlation of quantization noise vs correlation of quantizer input signals.

It can be seen that quantization noise is practically uncorrelated until the box size is one standard deviation and the input correlation is 95 per cent, or until the box size is two standard deviations and the input correlation is 80 per cent. A box size of two standard deviations corresponds to extremely rough quantization. The dynamic range of an input variable is practically three quantization levels. This is almost in the realm of switching circuits.

It can now be qualitatively stated that if the dynamic range of a variable being quantized extends over several boxes, the quantization noise will be uniformly distributed and will be a first order process. All moments will be the same as if the quantizer were a source of random independent noise.

Gathering and Processing Grouped Statistical Data

Statistical information is usually obtained by averaging the values of recorded numerical measurements. An approximate first-order distribution density may be had in the form of a histogram whose groups have width corresponding to the granularity of the data. Multi-dimensional histograms may be constructed from the same kind of data for higher-order processes. It is usually desirable to have some means of arriving at the original ungrouped distribution densities, particularly when the quantization is rough. This is perfectly possible when the Nyquist condition is satisfied. When the most significant part of the dynamic range of a smoothly-distributed variable covers about four or more quantization levels, the ungrouped distribution may be obtained with very small error in moments, as was shown above for the Gaussian statistics use. The "bars" of the histogram are "compressed" into impulses in the center of each group, then a minimum "bandwidth" envelope is passed through the impulse samples ["(sin X/X)" interpolation], and what results is the true ungrouped distribution convolved with $Q(n)$. Another way of acquiring the ungrouped distribution density having an analytic cf is to calculate its moments, which may be accomplished by means of Sheppard's corrections for first-order distributions. These corrections may be generalized for higher-order cases by treating the quantizer as a source of independent first-order noise distributed according to $Q(n)$.

An example of how properties of higher-order distributions are able to be obtained from roughly-quantized experimental data is the calculation of an autocorrelation function. Since the autocorrelation is a joint first moment, quantization is again equivalent to the addition of random independent noise. A two-bit autocorrelator could be used when the full dynamic range of a random variable is broken up into four quantization levels. Only negligible error will be made in a point on the autocorrelation curve as long as the correlation coefficient before quantization is less than 0.8. The quantization noise is uncorrelated. The only change necessary is the subtraction of $1/12 q^2$ from the mean square point. Mean squares of independent random waves add, and the mean square of quantization noise, the second moment of $Q(n)$, is one-twelfth of the square of the box size. Autocorrelations of data deliberately made crude have been calculated by the M.I.T. Whirlwind computer. All results show that autocorrelations obtained from rough data (2-bit accuracy) are equivalent to those taken from fine-grained data.

System Applications—Error Analysis

Two examples of closed-loop quantizer systems are shown in Fig. 18(a) and (b). The former has a quantizer in the feedforward section, while the latter has quantized feedback. The symbol "D" represents a linear sampled-data filter, one whose present output sample is a linear

combination of past and present input samples. Any sampled-data system having a single quantizer and a feedback path about it can be reduced to either form. These systems could represent situations ranging from crude contactor servos to very precise numerical difference-equation solution.

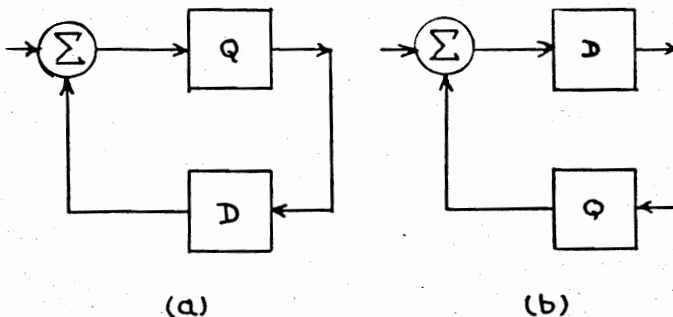

Fig. 18—Quantizer sample-data feedback systems.

The first problem to be considered when making a statistical analysis of these systems is that of testing the signal at the quantizer input for the satisfaction of the Nyquist condition. Elaborate and conservative methods have been devised for this, but the whole question practically reduces to whether or not the signal input to the quantizer has a dynamic range covering at least several quantization boxes.

Actual probability density distributions of the outputs of quantizers and quantizer systems are obtainable with varying degrees of difficulty depending on the natures of the systems and the statistics of their input signals. These include the effects of the causality of quantization noise. For example, the probability density of the output signal in Fig. 18(b) is continuous if appropriate Nyquist conditions are satisfied at both the input and output of the quantizer. The distribution of the system output is identical with that which would result if the quantizer were replaced by a source of random independent noise. On the other hand, the output distribution of Fig 18(a) is discrete, having a minimum bandwidth envelope corresponding to the distribution would result if again the quantizer were replaced by a source of random noise.

The moments of these distributions are far more readily obtainable because they depend only upon the moments of the signal and of the quantization noise. This was shown for the quantizer alone, and can be shown to apply generally to "linear" quantizer systems and certain non-linear ones. Thus, the moments of signal plus noise are obtainable by treating quantization as addition of independent random noise having the distribution density $Q(n)$.

In most situations, the quantization noise alone is of interest. The causal tie between noise and signal is of secondary importance. The distribution of the noise component in a system output is usually easy to calculate,

and once acquired, characterizes the effects of quantization in the system for the large class of input signals that allow satisfaction of the Nyquist condition at the quantizer input.

Once a quantizer is driven with an input that satisfies the Nyquist restriction, addition of another independent signal cannot change this situation. When their respective cf's are multiplied to give the cf of the sum, the result can be no wider than the narrower cf of the two constituents. In general, it will be even narrower than this and the restriction will be met more easily. In the amplitude domain, a quantizer having a sufficiently great dynamic range (extending over several quantization boxes) can only have this range increased by the addition of another independent input. Since the output of a quantizer is the same as the input plus an additive noise of fixed distribution $Q(n)$, the quantizer is "linearized" by any input component satisfying the Nyquist restriction. The same effects are realized with statistically related input components except where the addition of a component signal reduces the dynamic range already existing to one so small that the restriction is no longer met.

The system consequences of the "linearization" of a quantizer are similar to those for the quantizer alone. Here, the entire system is "linearized." For two input components, the quantizer output consists of the sum of three parts. Two of them are the respective output components of the linear equivalent system when driven by the two inputs. The third is due to quantization noise. It has a different waveform in time after the addition of the second input component, but has the same statistical characteristics as before.

According to the Central Limit Theorem, the addition of a good number of independent random quantities of arbitrary distribution yields a random process that becomes closer and closer to Gaussian as the number of included variables is increased. The output of a sampled-data filter at a given sample time is a weighed sum of past inputs that are often of a first-order process, so that statistical outputs of "long-memory" sampled-data systems are almost Gaussian. In particular, if the impulse response from a quantizer point to the output contains a half-dozen samples or more, a given noise output, the sum of that many independent past noises is nearly Gaussian. All that is needed to specify the first order distribution of the system output component due to quantization noise, then, is its mean square. Since the original quantization noise samples are independent, mean squares add. The mean square system noise is then $1/12 q^2$ times the sum of the squares of the impulse magnitudes of the response at the output to a unit impulse applied at the quantizer position.

As an example of a simple approach to an error analysis problem, consider the numerical solution of the homogeneous first-order nonlinear differential equation with its initial conditions:

$$\frac{dy}{dt} + y^2 = 0 \tag{13}$$

$$y(0) = 1.12.$$

An associated difference equation with a sampling interval of 1/10 is (14).

$$y_{k+1} = y_k - \frac{1}{10} y_k^2 \tag{14}$$

$$y_0 = 1.12.$$

The numerical point-by-point solution of this difference equation is given in Fig. 19. Notice that rounding after squaring greatly simplified the calculations and maintained the length of the numbers within three decimal digits. A block diagram showing the numerical solution scheme (including quantization) is Fig. 20(a). Fig. 20(b) gives the "small signal" response in y_k due to a unit impulse applied at the quantizer position. The "gain" of the squaring device is $2y_k$ which is taken to be approximately 2.

k	y_k	y_k^2	y_k^2 (rounded)	$y_{k+1} = y_k - \frac{1}{10} y_k^2$ (rounded)
0	1.12	1.2544	1.3	$y_1 = 1.12 - 0.13 = 0.99$
1	0.99	0.9801	1.0	$y_2 = 0.99 - 0.10 = 0.89$
2	0.89	0.7921	0.8	$y_3 = 0.89 - 0.08 = 0.81$
3	0.81	0.6561	0.7	$y_4 = 0.81 - 0.07 = 0.74$
4	0.74	0.5476	0.5	$y_5 = 0.73 - 0.05 = 0.68$

Fig. 19—Point-by-point solution to (14).

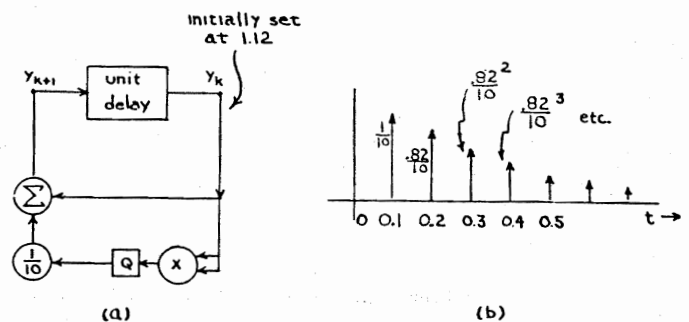

Fig. 20—(a) Block diagram of numerical solution. (b) "Small signal" unit impulse response from quantizer point to output.

The error to be expected in such a solution due to round-off may be predicted by replacing the quantizer of Fig. 20(a) by an independent noise source whose mean square is $1/1200$. The variance of the error in the fourth-output sample, for example, is

$$\frac{1}{1200} \left[\left(\frac{1}{10} \right)^2 + \left(\frac{0.82}{10} \right)^2 + \left(\frac{0.82^2}{10} \right)^2 + \left(\frac{0.82^3}{10} \right)^2 \right] = 20(10)^{-6}.$$

Thus the root mean square error in the fourth-output sample when averaged over several initial conditions in the vicinity of 1.12 will be less than 1 per cent of this sample.

CONCLUSION

A numerical abstraction or description of a continuous function of an independent variable may be made by plotting the function on graph paper, as in Fig. 21.

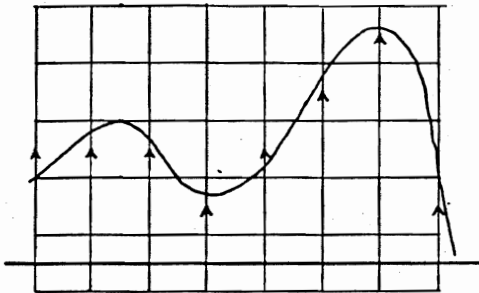

Fig. 21—Sampling and quantization.

Shown are the quantized samples of the function, a series of numerical values. This plot suggests that quantization should be like sampling in amplitude, which is indeed the case. Quantization is a sampling process that acts not upon the function itself but upon its probability density distribution. A Nyquist sampling theorem for quantization exists such that if the quantization is sufficiently fine, statistics are recoverable, whereas in conventional sampling, the Nyquist sampling restriction when satisfied insures that the function is recoverable.

Whenever the statistics are recoverable, the noise generated by the quantizer is well understood. This

knowledge allows one to answer questions such as, would it be better to sample less often and quantize finer, making use of the same amount of effort and equipment. When quantization takes place in a system, it is possible to predict the quality of performance in terms of the equipments used in achieving it.

ACKNOWLEDGMENT

The author wishes to thank Prof. W. K. Linvill for his assistance in this research. During the past several years, he has served as a combination of supervisor and father confessor. His method of approach to problems has had a most positive influence on the course of this thesis. The author also wishes to acknowledge the help of Profs. E. A. Guillemin and J. B. Wiesner who served as readers.

BIBLIOGRAPHY

- [1] Linvill, W. K. Class Notes for 6.54 (Pulsed-Data Systems). Massachusetts Institute of Technology, 1953.
- [2] Kochenburger, R. J. *Analysis and Synthesis of Contactor Servomechanisms*. D. Sc. dissertation, Massachusetts Institute of Technology, 1949.
- [3] Middleton, D. Class Notes for AM 215-216 (Applied Mathematics). Harvard University.
- [4] Linvill, W. K., and Sittler, R. W. *Design of Sampled-Data Systems by Extension of Conventional Techniques*. Massachusetts Institute of Technology Lincoln Laboratory Division 6, Report #R-222, July, 1953.
- [5] Cramer, H. *Mathematical Methods of Statistics*. Princeton N. J.: Princeton University Press, 1946.
- [6] Sheppard, W. F. "On the Calculation of the most Probable Values of Frequency-Constants, for Data arranged according to Equidistant Divisions of a Scale," *Proceedings of the London Mathematical Society*, vol. 29 (1898), p. 353-357.
- [7] Bowley, A. L. *Elements of Statistics*. London: P. S. King and Son, Ltd., 1937.
- [8] Bennett, W. R. "Spectra of Quantized Signals," *Bell System Technical Journal*, vol. 27 (July, 1948) p. 446-472.

